

Flow Measurement of gases and liquids

V31

- Housing in stainless steel
- Borosilicate glass
- Only 4 Sealing rings
- Service kind construction
- Replace V16 / V15 / V30
- Limit switches (Options)
- Chip guard

Operating principle

The measuring element is composed of a float and a conical glass tube.

A medium flows from the bottom to the top through the measuring ring, lifting the float until the buoyancy force and the weight of the float establish equilibrium. The height of the float in the measuring ring is the measure of the flow. The flow rate is read directly from a scale inscribed on the glass.

The readings obtained apply solely to the medium for which the device has been calibrated or for a medium with the same density and viscosity.

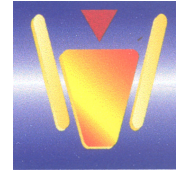

Applications

The V31 metering device is used for flow metering, dosing, monitoring, and control of liquid and gas media in pipes. The scale on the device shows the flow rate expressed as volume or mass per unit of time.

Applications: flow metering, dosing, monitoring, and control of liquid and gas media.

- The device can be fitted with up to two limit switches for purposes of process monitoring.



Technical Data

Measuring range	Turndown ratio		1:10
	Smallest measuring range	Water	6,5 - 65 l/h
		Air	150 - 1500 NI/h
	Largest measuring range	Water	1000 - 10000 l/h
		Air	18000 - 180000 NI/h
	Dimensions for measured variable	Water	
			m ³ /h >= 3000 l/h
Air			l/h <= 40000 NI/h
			m ³ /h >= 50000 NI/h
covered to 0 °C and 1,013 bar abs			
Accuracy class (according to VDE/VDI 3513, sheet 2)	Liquids		1,6%
	Gases		2,5%
			q _G 50%
Flow direction	from bottom to top		
Materials	Measuring tube	Borosilikatglas	
	Connections	1.4571, PVDF, PVC	
	Float	1.4571, Aluminium, PVDF	
	Float guiding	1.4571	
	Seals	Viton, EPDM, FEP/FFKM	
	Float Stop	PVDF / Edelstahl	
	Protection body	1.4301	
	Shatter protection	Acryl glas	
Ambient conditions	Ambient temperature	-20...+80 °C (-4...+176 °F)	
	Ambient temperature PVC	-20...+80 °C (-3...+176 °F)	
	Storage temperature	-20...+60 °C (-4...+140 °F)	
	Climatic category	Weatherproof and/or unheated operation site, class C according to DIN IEC 654 part 1	
Shock resistance / vibration resistance	The device should be protected against extreme shock and vibration, either of which could cause damage		
Medium Conditions	Pressure Resistance	Ranges C1 bis C7	max. 15 bar (at max. 80 °C ; 176 ° F)
		Ranges D1 bis D8	max. 10 bar (at max. 80 °C ; 212 ° F)
		Ranges E1 bis E5	max. 6 bar (at max. 80 °C ; 176 ° F)
		Connections in PVDF	max. 10 bar (at max. 20 °C ; 68 ° F)
			max. 4 bar (at max. 40 °C ; 104 ° F)
		Connections in PVC	max. 2,5 bar (at max. 50 °C ; 122 ° F)
	max. 10 bar (at max. 20 °C ; 68 ° F)		
	Media Temperature	Float made of 1.4571 / Aluminium / PVDF	-10 ° - +80 °C (+14 ° - +176 ° F)
		PVC Glue connection	-10 ° - +50 °C (+14 ° - +122 ° F)
	Status	liquid or gaseous	
	Density	Liquids	<=2,0 kg/l
		Gases	- / -
	Inlet and outlet straight	Inlet and outlet straight are not required as long as the flow profile is laminar. On strongly non laminar flow profiles e.g. regulating and shutoff devices inlet straight of 250 mm, see also directive VDI/VDE 3513	
Pressure Loss	see measuring ranges		

Limit contacts	Model	Switching type	Power
	K17A	reed contact N/O	AC 250 V / 0,5 A / 10 VA DC 250 V / 0,5 A / 5W
	K17B	reed contact N/C	
	K33	reed contact SPDT	250 V AC/DC/1,5A/150VA/100W
	K33i	inductive contact N/C	5-25 V DC

Measuring ranges

Liquids

V31 model	Connection Sizes <u>Standard</u>	Ranges acc. Range code	Pressure loss mbar(psi)	Float 1.4571 c/w and w/o guiding	Float 1.4571+ magnet	Float 1.4571 - viscosity stable	Float PVDF weighted w/o magnet
				Standard ranges for liquids - l/h - (p=1kg/l(62,43 lb/cu.ft), viscosity 1 mPas(1cp)) (turndown ratio 1:10)			
S 05	G 1/4" 3/8" 1/2"	C1	20 (0,290)	12,5 - 125	12 - 120	10 - 100	6,5 - 65
		C2		16 - 160	15 - 150	12,5 - 125	9 - 90
		C3		20 - 200	18 - 180	16 - 160	11 - 110
		C4		25 - 250	24 - 240	20 - 200	14 - 140
		C5	40 (0,580)	31,5 - 315	30 - 300	24 - 240	17,5 - 175
		C6		40 - 400	36 - 360	30 - 300	22 - 220
		C7		50 - 500	48 - 480	36 - 360	25 - 250
S 06	G 1/2" 3/4" 1"	D1	19 (0,280)	40 - 400	40 - 400	-	32 - 320
		D2		65 - 650	60 - 600	40 - 400	50 - 500
		D3		80 - 800	75 - 750	50 - 500	60 - 600
		D4		100 - 1000	95 - 950	60 - 600	75 - 750
		D5	24 (0,350)	120 - 1200	120 - 1200	75 - 750	100 - 1000
		D6		160 - 1600	150 - 1500	100 - 1000	125 - 1250
		D7		200 - 2000	180 - 1800	120 - 1200	160 - 1600
		D8	33 (0,480)	250 - 2500	240 - 2400	140 - 1400	200 - 2000
		D9		300 - 3000	280 - 2800	180 - 1800	240 - 2400
S 07	G 1" 1 1/4" 1 1/2" 2"	E1	25 (0,360)	400 - 4000	380 - 3800	250 - 2500	320 - 3200
		E2		500 - 5000	480 - 4800	300 - 3000	380 - 3800
		E3		650 - 6500	640 - 6400	400 - 4000	500 - 5000
		E4		800 - 8000	750 - 7500	450 - 4500	640 - 6400
		E5		1000 - 10000	950 - 9500	550 - 5500	750 - 7500

Gases

V31 model	Connection Sizes <u>Standard</u>	Ranges acc. Range code	Pressure loss mbar(psi)	Float Aluminum c/w and w/o guiding	Float Aluminum + magnet	Float PVDF	Float PVDF weighted or c/w magnet
				Standard ranges for air - NI/h - (Pabs =1,013 bar(14,69psi) at T= 20°C(68° F), p=1,293kg/m³, V=0,0181 mPas) (Turndown ratio 1:10)			
S 05	G 1/4" 3/8" 1/2"	C1	40 (0,580)	200 - 2000	250 - 2500	150 - 1500	200 - 2000
		C2		300 - 3000	320 - 3200	200 - 2000	300 - 3000
		C3		360 - 3600	400 - 4000	250 - 2500	360 - 3600
		C4		400 - 4000	500 - 5000	300 - 3000	450 - 4500
		C5		500 - 5000	640 - 6400	360 - 3600	600 - 6000
		C6		640 - 6400	800 - 8000	500 - 5000	700 - 7000
		C7		800 - 8000	1000 - 10000	550 - 5500	950 - 9500
S 06	G 1/2" 3/4" 1"	D1	19 (0,280)	750 - 7500	850 - 8500	520 - 5200	750 - 7500
		D2		1000 - 10000	1200 - 12000	800 - 8000	1000 - 10000
		D3		1300 - 13000	1500 - 15000	900 - 9000	1300 - 13000
		D4		1600 - 16000	2000 - 20000	1200 - 12000	1600 - 16000
		D5	24 (0,350)	2000 - 20000	2400 - 24000	1500 - 15000	2000 - 20000
		D6		2800 - 28000	3200 - 32000	2000 - 20000	2800 - 28000
		D7		3600 - 36000	4000 - 40000	2500 - 25000	3600 - 36000
		D8	33 (0,480)	4000 - 40000	5000 - 50000	3000 - 30000	4000 - 40000
		D9		5000 - 50000	6000 - 60000	3600 - 36000	5000 - 50000
S 07	G 1" 1 1/4" 1 1/2" 2"	E1	25 (0,360)	6400 - 64000	7500 - 75000	5000 - 50000	6400 - 64000
		E2		8000 - 80000	10000 - 100000	6500 - 65000	8000 - 80000
		E3		10000 - 100000	12500 - 125000	8000 - 80000	10000 - 100000
		E4		14000 - 140000	15000 - 150000	10000 - 100000	14000 - 140000
		E5		16000 - 160000	18000 - 180000	12500 - 125000	16000 - 160000

Construction details

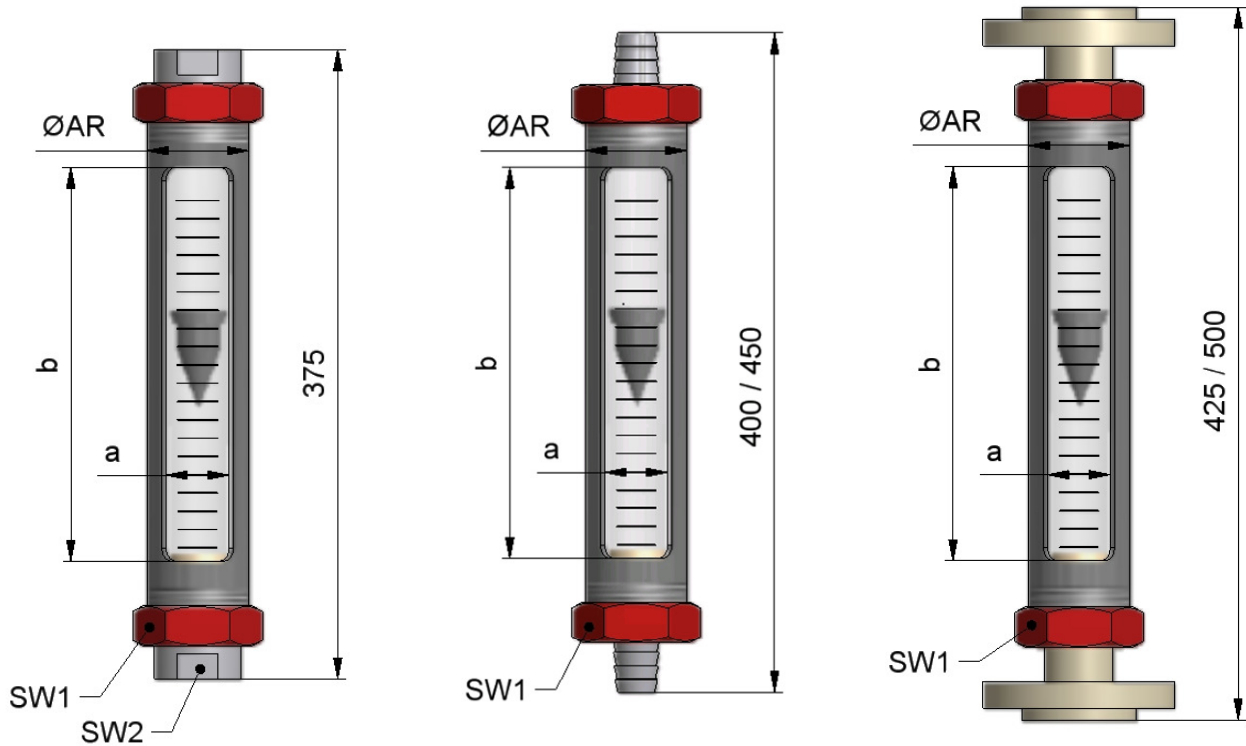

V31	Body					Anschlußart				
Range Code	ØAR	a	b	SW1	SW2	Female Thread connection	Hose connection	Glue connection	Flange connection	
S05	Ø33,7	19	235	39	24	G / NPT 1/4", 3/8", 1/2"	Ø13, Ø19	DN 15 d=20mm	DN 10/15/20/25 PN40	ASME 1/4", 3/8", 1/2" 150lbs
S06	Ø60,3	38	235	67	46	G / NPT 3/4", 1", 1 1/4"	Ø19, Ø25, Ø38	DN 32 d=40mm	DN 25/40 PN40	ASME 1", 1 1/2" 150lbs
S07	Ø88,9	58	235	100	65	G / NPT 1 1/4", 1 1/2", 2"	Ø38, Ø50	DN 50 d=63mm	DN 40/50 PN40 DN65 PN16	ASME 1 1/2", 2", 2 1/2" 150lbs

XX printed connections are standard



www.adinco.nl

Adinco bv

P.O.Box 90
4190 CB Geldermalsen
Netherlands

Tel. +31 (0) 345 59 60 00
Fax +31 (0) 345 59 60 01

E-mail: info@adinco.nl
Internet: www.adinco.nl